

Repair Parts For Use With V-3752 Normally Open Valves 1/2 Through 2 in.

Description

The available parts in the Selection Chart can extend the service life of the V-3752 Series of valves and return the valves to near original operating performance.

Selection Charts

Repair Parts for use with V-3752¹

Code Number	Call-out	Description
V-9999-608	A	Packing Kit
V-3752-646	B	Packing Nut
	C	Union Nut and Male Tailpiece Assembly for Valves with Union Connections
		Valve Size (in.)
V-3752-636		1/2
V-3752-637		3/4
V-3752-638		1
V-3752-639		1-1/4
	D	Stem and Swivel Assembly Includes Stem, Swivel, and Swivel Nut Lock Pin for Globe Valves:
		Valve Size (in.)
V-3752-6064		1/2
	E	Disc Assembly Includes: Disc, Disc Holder, Modulating Plug, and Three Pins for:
		Globe Valves
		Valve Size (in.) Seat Size (in.)Cv
V-3020-6045		1/2 3/80.9
V-3020-6047		1/2 3/81.8
		Union Angle Valves
		Valve Size (in.) Seat Size (in.)Cv
V-3020-6045		1/2 3/81.1
V-3020-6047		1/2 3/82.5
	F	Disc Only:
		Valve Size (in.)
V-3020-6021		1/2
V-3752-6047		3/4
V-3011-6001		1
V-3011-6002		1-1/4
	G	Union Globe Body Only:
V-3752-6004		3/4
V-3752-6005		1
	æ	Inner Valve and Spring Assembly for:
		Globe Valves
		3 to 6 psig Spring
		Valve Size (in.) Cv
V-3752-6050		1/2 0.9
V-3752-6051		1/2 1.8
		Union Angle Valves
		3 to 6 psig Spring
		Valve Size (in.) Cv
V-3752-6052		1/2 2.5

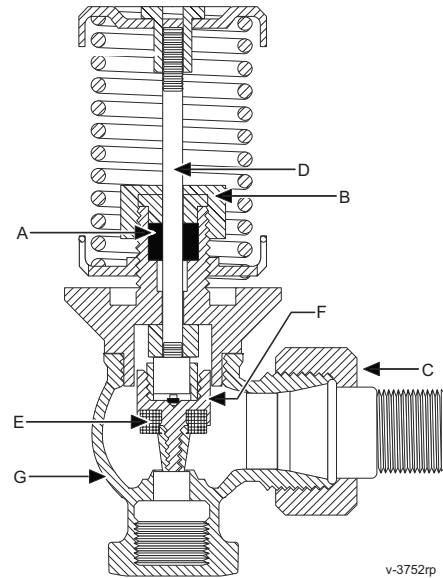

Repair Parts, V-3752

Spring Kits and Recondition Kits for V-3752¹

Code Number	Valve Size (in.)	Actuator Size	Spring Range (psig)	Spring Kit ²	Recondition Kits ³
V-3752	1/2	V-3000	3-6	V-3752-6023	---
			9-13	V-3752-6022	
	3/4		3-6	V-3752-6023	V-3752-6016 (C _v = 3.7) or
			9-13	V-3752-6022	V-3752-6027 (C _v = 3.8)
	1.		3-6	V-3752-6024	V-3752-6017 (C _v = 7) or
			9-13	V-3752-6021	V-3752-6028 (C _v = 7)
	1-1/4		3-6	V-3752-6024	V-3752-6018 (C _v = 12) or
			9-13	V-3752-6021	V-3752-6019 (C _v = 12)
	1-1/2		3-6	V-3754-6010	V-3752-6020 (C _v = 20) or
			9-13	V-3754-6009	V-3752-6030 (C _v = 20)
	2		3-6	V-3754-6010	V-3752-6034 (C _v = 35) or
			9-13	V-3754-6009	V-3752-6031 (C _v = 26)

- The 1/2 through 2 in. size valves of this model were discontinued in 1979.
- Spring Kit Includes: Spring, Upper & Lower Spring Seat, Stem Extension, Stem Lock Screw, and Instructions.
- Recondition Kit Includes: O-ring, Swivel Nut, Washer, Disc, Disc holder, Contoured Disc Retainer, Pins, Swivel, Spacer, Stem, Bonnet, Packing, Packing Nut, and Instructions unless otherwise noted.

1. The 1/2 through 2 in. size valves of this model were discontinued in 1979.